

# DVP Peripheral Series Frequency Measurement Card Instruction Sheet

## 1 WARNING

- Warning 1:** This frequency measurement card is a specific function card for DVP-EH PLC, please use this card with DVP-EH MPU.
- Warning 2:** Frequency measurement card is an OPEN TYPE without any mechanical shield. When installing this card, user is supposed to power off the MPU and take precaution against static (anti-static glove) to prevent the surface parts of the card from being damaged.
- Warning 3:** Do NOT connect the AC power line to any of the input/output terminals, or it will damage the PLC. Make sure all the wiring is correct before power on.
- Warning 4:** To enhance the anti-interference performance of product, please make sure terminal FG is properly grounded.
- Warning 5:** Frequency measurement card is only workable for the DVP-EH with the version greater than 1.1.

## 2 INTRODUCTION

- Thank you for choosing Delta DVP series product. The frequency measurement card (DVP-F2FR) is the function card with 2 external inputs that accept digital signals. By using FROM-TO instruction, PLC can read/write the data or parameter in the frequency measurement card.
- There are 255 built-in CRs (Control Register) in DVP-F2FR with 16 bits for each register. DVP-EH MPU can control the function of DVP-F2FR by programming the CRs.
- Nameplate Explanation:

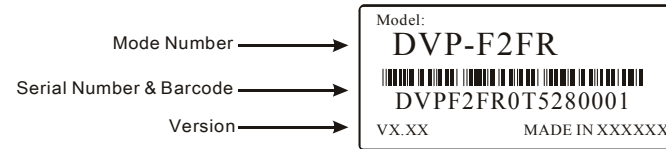

### Serial Number Explanation:

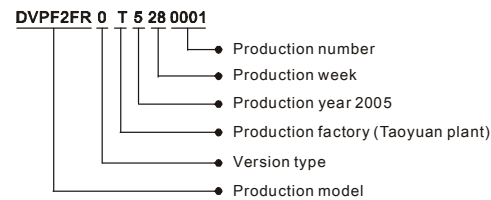

### Product Outline:

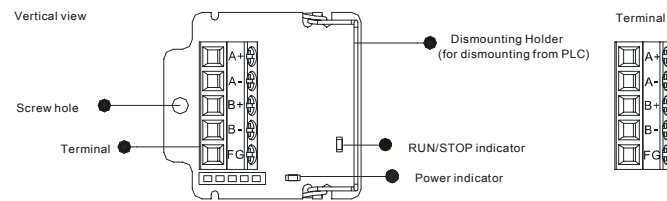

## 3 SPECIFICATION

### 3.1 Basic Specification:

Input Signal	Electric Level	Terminals [A+] & [A-], [B+] & [B-]: DC22~30V, 8~12mA. SINK or SOURCE	
	Pulse Type	<p>t1: rising/falling time <math>\leq 0.8\mu s</math> t2: ON/OFF pulse bandwidth <math>\geq 2.5\mu s</math> t3: phase difference of A, B phase <math>\geq 1\mu s</math></p>	
Storage and Environment	Storage	-25°C~70°C (Temperature), 5~95% (Humidity)	
	Operation	Operation: 0°C~55°C (Temperature), 50~95% (Humidity), Pollution degree: 2	

### 3.2 Operation mode:

There are 3 types of operation mode for the frequency measurement card. User can decide the operation mode by setting CR1. Detail information as follows:

#### Mode 1: Pulse Interval Length Measurement (CR1=K1)

- Measurement method of pulse interval:

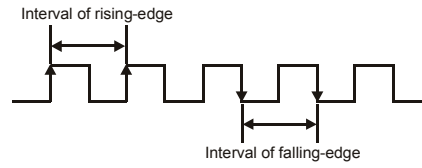

- Inputs of pulse interval measurement: F0, F1.
- Time unit of pulse interval measurement: 50ns, 100ns.
- Interrupt function: I180 will be executed after frequency measurement card detects rising edge or falling edge in F0 and F1. And bit 0 of CR9 will inform interrupt trigger by F0 while bit1 of CR9 by F1. For more information, please see section 6.1.
- Input frequency range: 1Hz~1kHz.
- Accuracy:  $\pm 0.01\%$  (max.)

#### Mode 2: High-speed Counter (CR1=K2)

- There are 3 types for mode 2 the high-speed counter. The maximum input frequency of Pulse/Direction can be up to 200kHz. Explanation as follows:

- Pulse/Direction: F0 is pulse input point. F1 is the signal to control the count-up or count-down. Counting method is shown as diagram as follow:

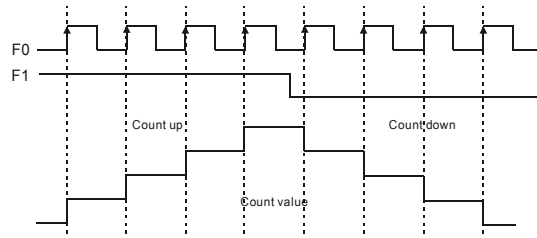

- A/B-phase two times frequency: F0 is the input pulse of A phase and F1 is the input pulse of B phase. Counting method is shown as follow:

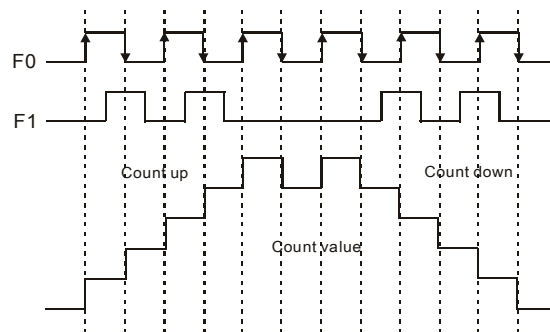

Value	F0 (A phase)		
	Rising-edge	Falling-edge	
F1 (B phase)	High	Count-down	Count-up
	Low	Count-up	Count-down

- A/B-phase four times frequency: F0 is the input pulse of A phase and F1 is the input pulse of B phase. Counting method is shown as follow:

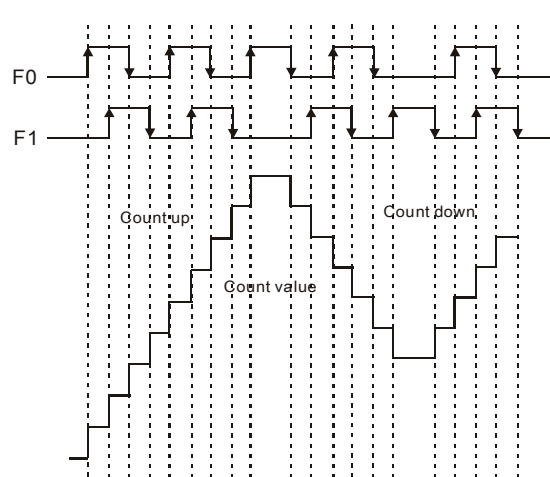

Value	F0		Value	F1			
	Rising-edge	Falling-edge		Rising-edge	Falling-edge		
F1	High	Count-down	Count-up	F0	High	Count-up	Count-down
	Low	Count-up	Count-down	F0	Low	Count-down	Count-up

#### Mode 3: Pulse Number Capture (CR1=K3)

- Input point: F0 is pulse input point. F1 is the signal to capture pulse number.
- Following diagram show the count method of pulse number:

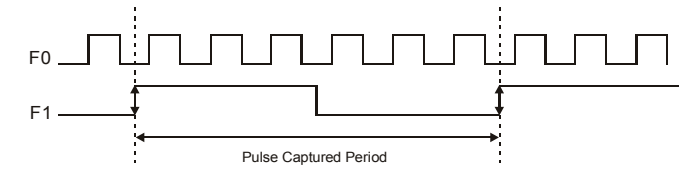

- The calculation of the pulse numbers for F0 is based on the interval between two rising edge or falling edge of F1.
- Interrupt function: when PLC set M1019 (flag of operation mode setting for frequency measurement card) and D1034 (flag of operation mode setting for frequency measurement card) to set up operation mode, I180 will be triggered based on the rising-edge or falling-edge of F1. If PLC has I180, it will execute I180.
- Accuracy:  $\pm 1$  pulse.

## 4 CONTROL REGISTER

- DVP-EH MPU perform read/write operation to the CR via programming FROM-TO instruction.

- CR will re

### Control Register Explanation Table:

CR NO.	HW	LW	Attribute	Factory setting	Latched	Mode	Function explanation		
#0		R	H2A0		×		System default, read only, number=H'2A0		
#1		R/W*	K0	×			Frequency measurement card execution mode		
							K1 (mode 1)	K2 (mode 2)	K3 (mode 3)
							Pulse interval measurement	High-speed counter	Pulse number capture
#2		R/W	K0	×	1,2,3		Frequency measurement card Run of Stop		
							K0	K1	
#3		R/W*	K0	×	1,3		F0 record item (range 0~40)		
#4		R/W*	K0	×	1,3		F1 record item (range 0~40)		
#5		R/W*	K0	×	1,3		Trigger by rising edge or falling edge rising edge=0, falling-edge=1		
							CR5 Low byte	CR5 High byte	
#6							Reserved		
#7		R/W*	K2	×	1		F0 measure time unit		
#8		R/W*	K2	×	1		F1 measure time unit		
#9		R	K0	×	1		Mode 1: interrupt trigger flag		
							When F0 trigger I180, bit0 of CR9 will be ON.		
							When F1 trigger I180, bit1 of CR9 will be ON.		
							When PLC read CR10~CR11, bit0 of CR9 will be OFF.		
#11	#10	R	K0	×	1		F0 pulse interval measurement		
#13	#12	R	K0	×	1		F1 pulse interval measurement		
#15	#14	R	K0	×	1		F0 value of frequency floating point		
#17	#16	R	K0	×	1		F1 value of frequency floating point		
#19	#18	R	K0	×	1		F0, F1 rising-edge or falling-edge, time difference		
#21	#20	R/W	K0	×	2		High-speed counter value		
							High-speed counter value won't be cleared when frequency measurement card stop		
#22		R/W*	K0	×	2		High-speed counter mode		
							K0	K1	K2
							Pulse/Direction	A/B phase two times frequency count	A/B four times frequency count
#23		R	K0	×	2		Indication flag of count up or count down		
							K0	K1	
#24		R/W	K0	×	2		Flag of start-up counting of high-speed counter		
							K0	K1	
#26	#25	R/W	K0	×	3		Number of captured pulse		
							Method of pulse count		
#27		R/W*	K0	×	3		K0		
							Pulse number non-accumulated	Pulse number accumulated	
#28		R/W	K0	×	1		F0 time-out setting (K0~K32767)		
#29		R/W	K0	×	1		F1 time-out setting (K0~K32767)		
#30~#32 Reserved									
#33		W*	K0	×			Return to factory setting		
#34		R	K0	×			When writing "1" into CR33, all the CR of frequency measurement card will return to factory setting and modify former "1" as "0". Version explanation: high byte is the value in the left side of decimal and low byte is the value in the right side of decimal. e.g. H1000 is		

CR NO.	HW	LW	Attribute	Factory setting	Latched	Mode	Function explanation
							V1.00 version.
#35~#49							Reserved
#50	R		K51	x		1,3	The index of F0 record value (record the number from CR51~130)
#51~#130	R		K0	x		1,3	F0 record value (each value occupy 2 group CR)
#131	R		K132	x		1,3	The index of F1 record value (record the number from CR132~211)
#132~#211	R		K0	x		1,3	F1 record value (each value occupy 2 group CR)
#222~#255							Reserved

- The usage of CR varies based on operation mode. Please follow the table above to read or write CR.
- In column Attribute, "\*" means writing is allowed when frequency measurement card is not working.
- When the writing value is out of available range, the value of upper/lower bound shall prevail to write once the value is out of upper/lower bound.
- The CR28 and CR29 are the time-out setting for F0 and F1. When setting them to a non-zero value in mode 1, it will monitor the signal input from F0 or F1 and start a time-out counting. If no signal detected in F0 and F1 with the time-out counter reaching the setting, it will clear the CR10~CR11 or CR12~CR13 and inform the PLC by I180 interrupt. Moreover, when CR28 and CR29 are set to zero, the time-out counter will not work anymore.
- CR50~CR211 will record the value according to the operation mode. Explanation as follows:

	Mode 1	Mode 2	Mode 3
CR51~CR130	To record F0 pulse interval (CR10, CR11)	N/A	N/A
CR132~CR211	To record F1 pulse interval (CR12, CR13)	N/A	To record F1 pulse interval (CR25, CR26)

- The index number of each record is plus 2 for CR50 and CR131 after both registers record on next. Once the index number reaches to the maximum, it will back to the 1<sup>st</sup> index number.
- It takes about 125us for instruction FROM/TO to read or write a CR of the frequency measurement card. One more read/write item of CR, 30us more for register.

## 5 INSTRUCTION EXPLANATION

### 5.1 Instruction Explanation for Frequency Measurement Card

API										
78	D	FROM	P	(m1)	(m2)	(D)	(n)	Read Special Module CR Data		

- Instruction Explanation
- (m1): Number of special module (m1=0~7). Number of frequency measurement card, m1=200.
  - (m2): Number of CR of special module that will be read.
  - (D): Location to save reading data.
  - (n): Data number of reading one time.

API										
79	D	TO	P	(m1)	(m2)	(S)	(n)	Special Module CR Data Write In		

- Instruction Explanation
- (m1): Number of special module (m1=0~7). Number of frequency measurement card, m1=200.
  - (m2): Number of CR of special module that will be read.
  - (S): Location to save writing data.
  - (n): Data number of reading one time

### 5.2 Explanation of special D, M and Interrupt:

Device	Explanation	Range
D1034	Mode setting of frequency measurement card	D1034 = K1~K3 (Mode 1~Mode 3)
M1019	Flag of mode setting	
I180	Frequency measurement card trigger interrupt	

- After PLC run at the first scan time, PLC will detect flag M1019 is ON or OFF. If M1019 is ON, PLC will modify the frequency measurement card's operation mode based on D1034 setting. Program example as follow is operation mode 1:

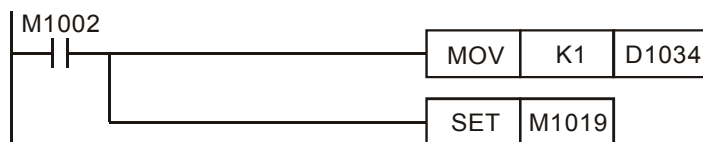

- PLC can use M1019 (flag of operation mode setting for frequency measurement card) and D1034 (flag of operation mode setting for frequency measurement card) to set operation mode 1 (measurement of pulse interval) and operation mode 2 (measurement of pulse number) to support Interrupt function I180.

## 6 APPLICATION EXAMPLE

### 6.1 Pulse Interval Length Measurement

- Following the program example of setting operation mode 1 (D1034, M1019) for frequency measurement card. For F0 and F1, set the time unit of sampling rate is 100ns (D7, D8) and the sampling record number as 20 (D3, D4). Moreover, I180 will be triggered when F0 or F1 detects a rising or falling edge. PLC can read CR9 via instruction FROM to decide which channel to detect the signal.

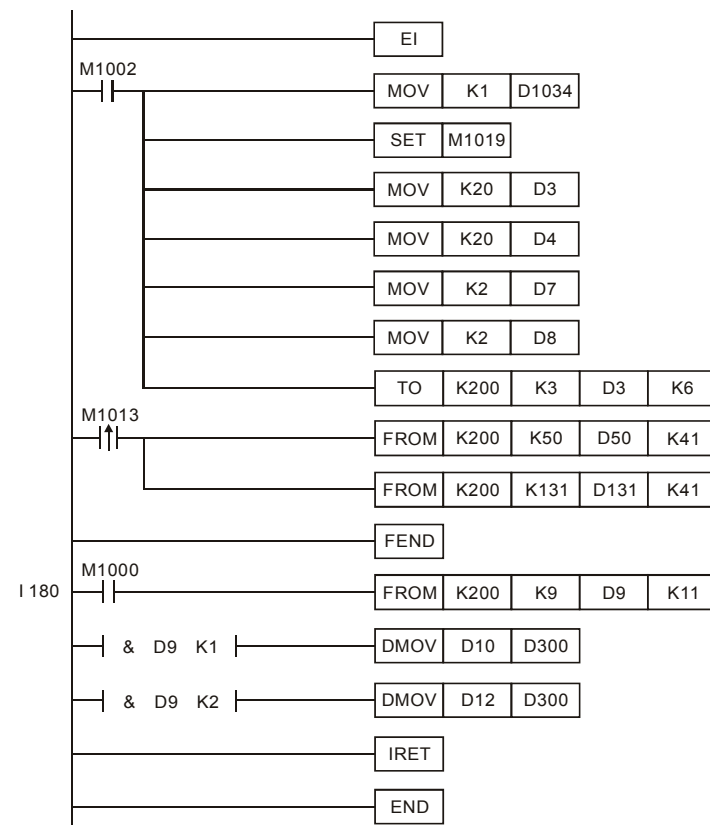

### 6.2 High-speed Counter

- The setting for the following program example:
  - Operation mode: Mode 1.
  - Counting method: Pulse/Direction.
  - Set M0=ON to start counting.

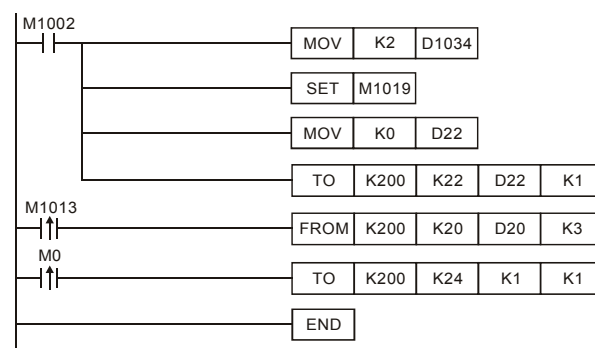

### 6.3 Pulse Number Capture

- The following program example is Mode 3 for frequency measurement card. Whenever frequency measurement card detects the rising-edge in F1, it will trigger the Interrupt I180 of PLC. When PLC execute Interrupt I180, it will read the content of CR25, 26 of frequency measurement card via instruction FROM.

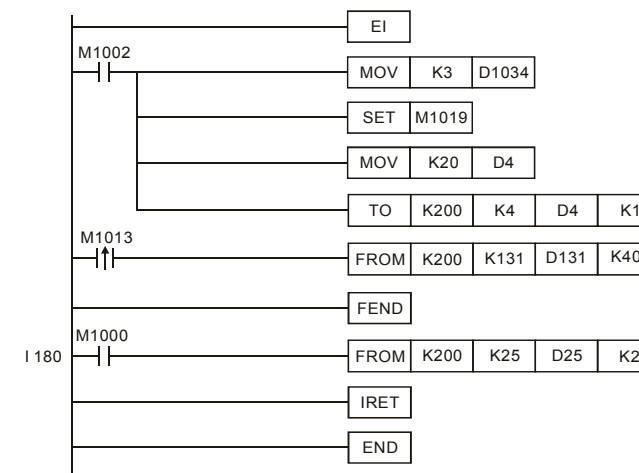

### 6.4 Differential Input Interface (please refer to the following wiring method)

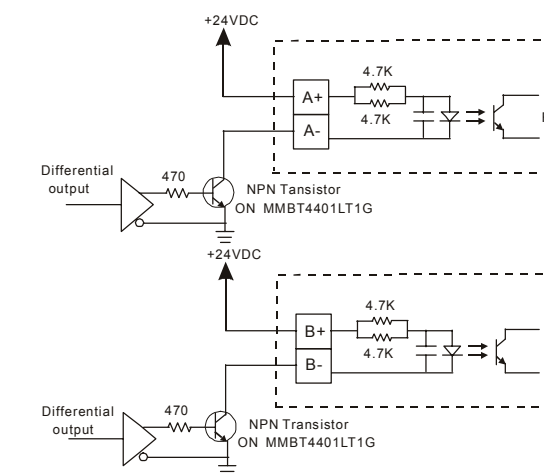

- Suggestion: if it is necessary to measure the input signal of frequency measurement card, please connect one clip of the oscillograph probe to either terminal A- or B- and the other clip of the oscillograph probe to the ground.

## 7 INSTALLATION AND MAINTENANCE

### Wiring Method for Frequency Measurement Card

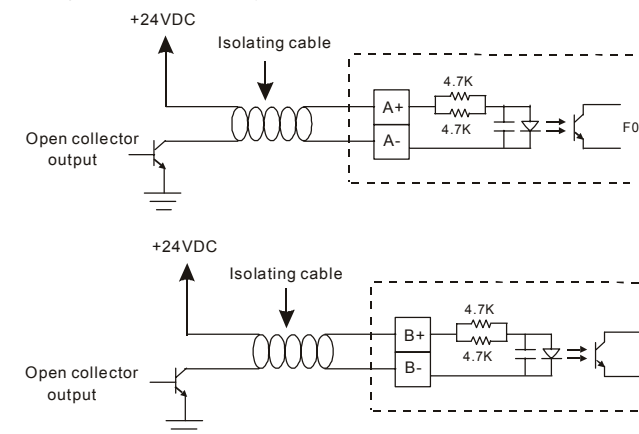

- There is a SDSP1 indication LED in the front end of the DVP-F2FR frequency measurement card. When power on the PLC MPU, the LED will light up (green). If the LED doesn't light up with power on, it means that there is error with the card. Please power off the PLC and re-install the card again.
- Before power on the system, please check A/B phase loop and make sure they connect to the input terminal with correct electrical level.